

Series 0512 Pruner

I. Picture

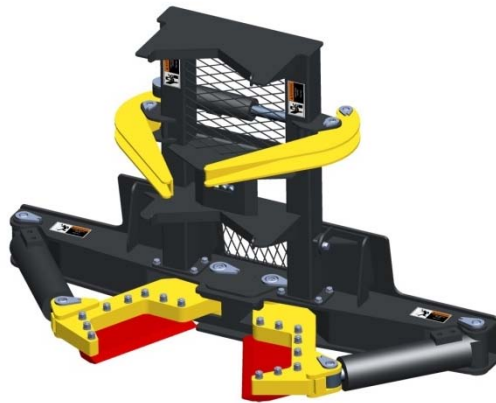

II. Main technical parameters of product:

Model	051212	051216
Total width (mm)	1900	2300
Total height (mm)	1255	1455
Total length (mm)	860	895
Pruning diameter (mm)	•• 300	•• 400
Total weight (including hanging parts) (Kg)	765	870
Allowed maximum pressure (Mpa)	21	21
Operating flow (L/Min)	50-75	50-75
Operating voltage (V) (optional)	DC12/DC24	DC12/DC24
Applicable main engine	Skip steer loader/small loader	

III. Main characteristics of product

Applicable to a skip steer loader or a mini-loader for tree pruning operations.

Through the stretching and contraction of the hydraulic cylinder, the scissor is driven to close or open, with stable



and powerful motion as well as safe and reliable operation, greatly reducing the labor intensity of the operation personnel.

Equipped with a clamping mechanism, ensuring reliable and convenient operation.

If it is equipped on a small loader, the client shall independently install the position limiter for bucket tilt-back and the skip bucket as per the condition of the main equipment.

Note: HCN products are constantly updated and improved for users. Rights to change the parameters and design are reserved without notifying the users in advance. In case of possible appearance and color differences between the products shown in the pictures and the actual products, the actual one shall prevail.