



HCN ATTAMCHMENTS CONTENT YOUR NEED

PRODUCT USER MANUAL

Our contact information:

Address: No.1 Huake Road, Xuzhou Economic and
Technological Development Zone,
Xuzhou, China

Postcode: 221004

Tel: 0516-66881280 66881281

Fax: 0516-66881272

Website: <http://www.hcn-atta.com>

Model Name: 0203-breaker hammer

Preparation date: 2024.06.07

XUZHOU HCN ATTACHMENT MANUFACTURE CO., LTD.

Warm reminder:

Please read the manual carefully before installing and using the product.

CATALOGUE

1. Safety Instruction	2
2. Products Instruction	3
3. Operation Instruction	4
4. Brazing Rod Introduction	5
5. Inflating instructions	5
6. Maintenance Instructions	6
7.Storage Instructions	7
8.Troubleshooting and diagnosis	7

1. Safety Instruction

1. Before using this equipment, please read this instruction manual and the accompanying crushing hammer body instruction manual carefully.
2. Before using this equipment, please know the working capacity, size and operation procedure of this equipment.
3. The working environment of the equipment requires; flat ground and open view.
4. Before operation, the operator should wear protective gear.
5. Before using, please check the crushing hammer to ensure that all fasteners are connected reliably, and the hose and joints are not leaking, and when using for the first time, check whether all fasteners are loosened every two to three hours.
6. Before starting, observe the surrounding area and make sure that there is no obstacle to the safety of driving, then sound the horn first and then start.
7. Prohibit personnel from approaching at close range during the crushing operation.
8. The operator shall not operate the machine under the condition of drunkenness, otherwise it will reduce the ability to judge the danger signals.

9. Prohibit lifting and hoisting operations with crushing hammers to avoid falling accidents from a height.

10. Switch off the engine before maintenance, do not touch any part of the crushing hammer before the hydraulic oil cools down, and replace any damaged parts in time.

11. Check whether all the warning signs are clean and clear, and replace them in time if they are damaged.

12. Do not disassemble and modify the crushing hammer without permission, and prohibit the use of non-original brazing rod.

2. Products Instruction

1、Product Structure

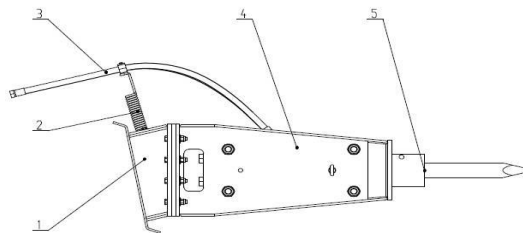

- 1-Support bracket 2-Oil pipe support 3-Hose assembly
4-Side support 5-Hammer body

Model	020375	020370	020353	020345
Overall length (mm)	1200	1200	1200	1200
Overall width (mm)	812	809	747	747
Total height (mm)	2036	1692	1493	1431
Brazing rod diameter (mm)	φ75	φ70	φ53	φ45
Working flow rate (L/min)	35-65	30-45	25-45	25-40
Working pressure (bar)	110-160	110-160	110-140	110-140
Impact frequency (bpm)	500-700	500-800	500-900	500-1000
Nitrogen chamber air pressure (Kg/cm ²)	14-16	14-16	14-16	14-16
Weight (Kg)	447	341	231	200
Applicable models	6-9T excavator or	4-7 T excavator	2.5-4.5T excavator	1.2-3T excavator
Note: The product default Shun Tian hammer core, have special requirements, please note in the order!				

Note: The shape of the product will vary depending on the adapted host.

3. Operating instructions

1. In order to give better play to the crushing force, the brazing rod must be placed in a suitable position, otherwise it will weaken the impact of the piston and not be able to crush the stone sufficiently. And it will cause the body of the crushing hammer and the big and small arms of the main machine to be impacted, which may lead to damage of the parts.

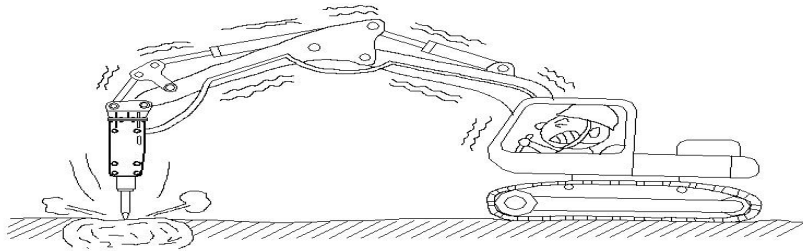

2. The brazing rod is as perpendicular as possible to the surface of the rock on which the work is to be done; if it is not perpendicular, the brazing rod may slip during the work. When crushing, first fully adjust the brazing rod and then, under stable conditions, carry out the striking operation.

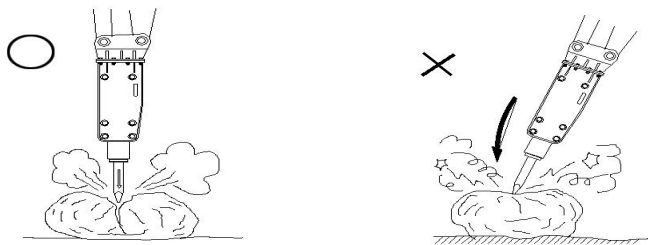

3. It is strictly prohibited to use brazing rod or crushing hammer side tamping, pushing, prying, lifting and other non-normal way of operation.

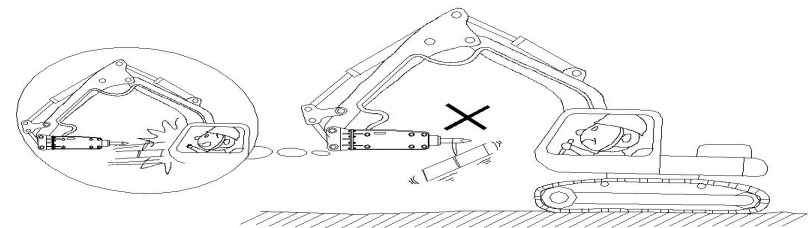
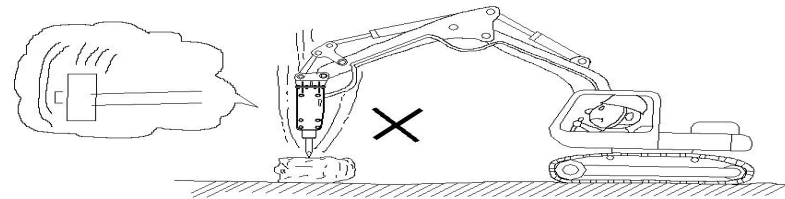
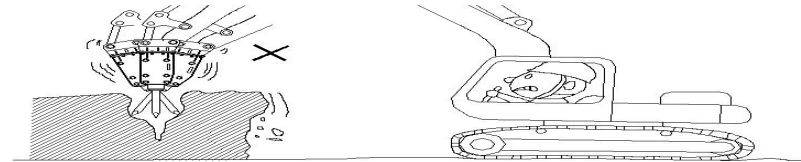
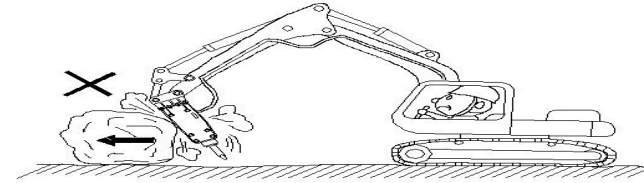
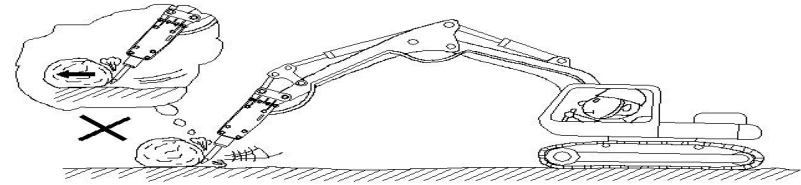

4. It is prohibited to put the crushing hammer directly into the water or silt operation, so as not to cause damage to the hammer body.

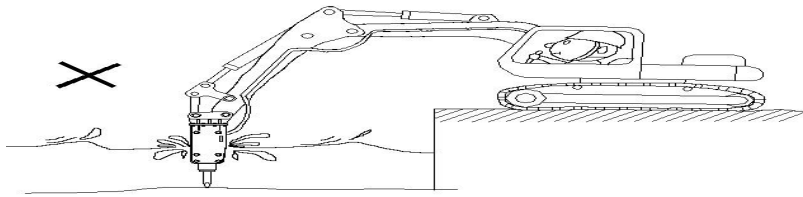

5. When striking the material, align the brazing rod vertically with the striking surface and apply pressure, and stop the operation immediately after the material is crushed, as empty striking will cause damage to the front cylinder and loosening of the bolts. After 30 seconds to 1 minute of impact crushing on the same point, if the rod still fails to crush the object, please change the position of the striking point.

6. Do not drive the rod all the way into the object to be crushed during the crushing operation.

7. Do not operate the hammer when the piston rod of the main cylinder is in the limit position.

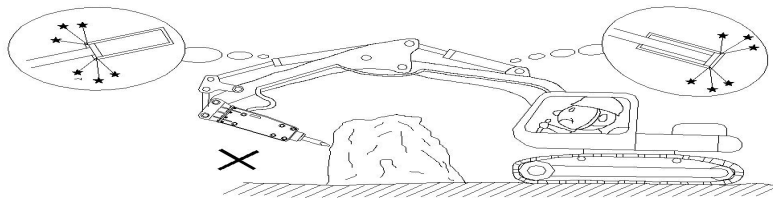

8. The engine should be warmed up for 5-10 minutes at 30°C-40°C before working in low temperature environment. When working under high temperature conditions, when the oil temperature is higher than 80°C, the operation should be stopped immediately or a cooler should be installed.

1. 9. When leaving the host, the crushing hammer should be placed flat on the ground first, and the host is switched off or in neutral gear.

4. Brazing Rod Introduction

1.Replacement of brazing rod

1) Lay the hammer flat, clean the oil inside the stop pin, then use the cross pin punch to knock out the stop pin from the opposite side of the rubber plug.

2) Remove the brazing rod by knocking out the brazing rod pin with a cross pin punch.

3) When installing the brazing rod, please apply lubricating grease to the groove surface of the brazing rod, and then install it in the reverse order of disassembly.

2.Brazing rod pin replacement

1) Serious deformation of the brazing rod pin will make it difficult to replace the brazing rod, so every 100-150 hours of work, please swap the face of the brazing rod pin contacting the brazing rod, and if there is any burr, please grind it down and use it.

5.Inflating Introduction

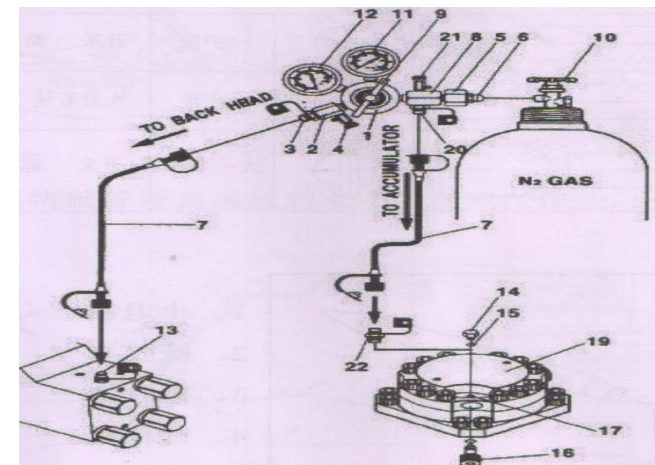

1. Rear Cylinder Filling

- 1) Make sure the exhaust valve (4) and air valve (10) are closed, then connect the nut (5) to the nitrogen bottle.
- 2) Make sure the handle (9) is fully open.
- 3) Connect both ends of the hose (7) to the micro connector (3) and the rear micro connector (13).
- 4) Open the air valve (10) and turn the handle clockwise to inflate.
- 5) Adjust the handle (9) to direct the rear pressure gauge to show the specified pressure.
- 6) If the rear pressure is higher than the specified value, open the bleeder valve (4) to lower the pressure.
- 7) Close the air valve (10), open the bleeder valve (4) to carefully drain the gas from the hose (7) and remove it.

2. Accumulator filling

- 1) Ensure the air valve (21) and air valve (10) are closed and connect the nut (5) to the nitrogen bottle.
- 2) Make sure the handle (9) is fully open.
- 3) Remove the accumulator filling plug (14) and O-ring (15) and store them properly.
- 4) Connect the miniature connector (22) to the inflation port (17).
- 5) Connect both ends of the hose (7) with the micro fittings (20, 22).
- 6) Open the accumulator inflation valve (16) by turning it half a turn anti-clockwise.
- 7) Open the air valve (10), inflate the accumulator, instruct the pressure gauge on the accumulator to show the specified value, open the exhaust valve (21) to slowly reduce the pressure.
- 8) Close the accumulator filling valve (16) after filling.
- 9) Close the air valve (10), open the bleeder valve (21) and slowly drain the gas from the hose (7).
- 10) Remove the miniature connector (22) from the accumulator, install the

plug wire (14) and O-ring (15), and close the accumulator filling hole.

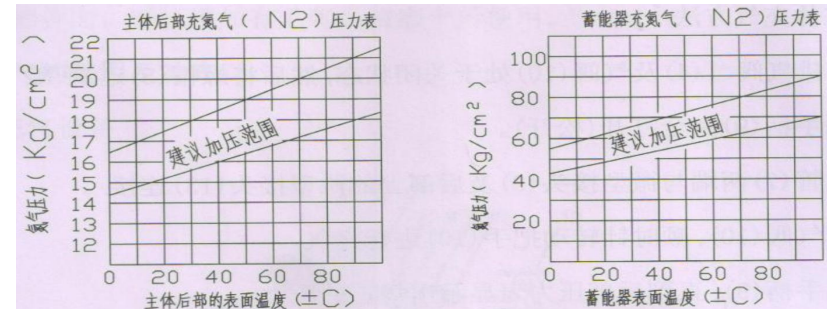

6. Maintenance instructions

Careful and thorough maintenance will keep this machine in good working condition. Regular maintenance is the key to keep the long life and safe working of the machine, the maintenance items described below are more important.

1. Every day before use, check each fastener, oil pipe and joint for looseness, check the surface of the hammer core for oil leakage, and check the brazing rod for cracks and abnormal wear. Check the pressure of nitrogen chamber and accumulator every fortnight.
2. When it is necessary to replace the parts, only the parts approved by the manufacturer should be used.
3. The nitrogen chamber and accumulator can not be filled with any gas other than nitrogen.
4. Refill the grease every 2-3 hours, when refilling, make sure to stand up the hammer and inject the grease under the condition of the brazing rod being pressed into the front cylinder completely.
5. Every 100-150 hours of work, the 2 sides of the brazing rod pin will be

interchanged, and the wear surface will be polished smooth.

6. Replace all hydraulic seals every 400 hours of operation.
7. Every 500 hours of work to replace the hydraulic oil, summer with 68 hydraulic oil, winter with 46 hydraulic oil, and the use of the same brand of fluid, mixed fluid may deteriorate, damage to the hydraulic system.
8. Replace the oil filter every 100 hours of work.
9. Brazing rod and the front part of the bushing with the part, brazing rod diameter wear more than 3mm, the front part of the bushing wear more than 6mm need to be replaced.

7.Storage instructions

1. All debris, dirt, and grease should be removed from the machine after the operation is completed.
2. The implements should be stored in a dry and non-corrosive environment to avoid rust and corrosion on the surface of the implements.
3. When the machine is placed, there should be a fixed positioning bracket, so that when it is activated next time, it is convenient for the host and the machine to be connected.
4. When storing the hammer, the end of the brazing rod should be lower than the end of the nitrogen chamber to avoid rusting of the piston caused by the backflow of rainwater. When the hammer is not in use for a long time, please release the nitrogen in the nitrogen chamber, put the piston back into the cylinder, put the plug on the oil pipe, clean the front head of the hammer and apply anti-rust oil. Piston corrosion does not belong to the quality problem, oil leakage and strain caused by piston corrosion will not be claimed!

8.Troubleshooting and diagnosis

If the crushing hammer does not work or the striking frequency or striking force drops drastically, check whether the installation method is correct, and then overhaul according to the following items.

Malfunction	Reason	Measure
Non-working	High air pressure in nitrogen chamber	Adjust the air pressure to the specified pressure
	Damaged piston, cylinder, reversing valve	Recondition contact surfaces with sandpaper
	Damaged oil seal retainer seal	Replace seals
	Seized directional valve	Repair the reversing valve
	Insufficient oil	Replenish hydraulic oil
	Brazing rod and rod pin seized	Repair rod and pin
	Low relief valve pressure	Adjust relief valve pressure to normal
Wrong oil pipe connection	Check oil pipes	
Strike force weak	Nitrogen chamber/accumulator pressure too low	Check air pressure
	Insufficient hydraulic fluid	Replenish hydraulic oil
	Damaged braze rod	Recondition damaged brazing rods and bushings
	Abnormal safety set pressure or relief valve	Check set pressure
	Clogged oil return filter	Clean or replace filters
precariousness of	Air pressure in the nitrogen chamber is too high	Check air pressure
	Accumulator pressure is low or bowl is damaged	Check air pressure or replace bowl
	Damage to braze rods, front section	Repair damage to rods and

blows	bushings	bushings
	Damage to piston, cylinder, reversing valve	Recondition contact surfaces with sandpaper
	Low operating pressure	Adjust relief valve pressure
Oil leakage from front cylinder block or brazing rod	Worn cylinder seals	Replacement of seals
Air leaks--Leak at charge valve	Damaged bushing o-ring	Replacement
Air leaks--Air leak at boost valve body	Damaged filler valve o-ring, untightened filler valve	Replace or tighten the inflation valve
Air leaks--Air leakage between mid block and rear block	Loose cylinder bolts	Tighten the cylinder bolts
Air leaks--Air leak at nitrogen seal	Damaged nitrogen seals (if there are bubbles in the oil after the oil return hose is pulled off, the nitrogen seals are damaged).	Replace the nitrogen seals
Sharp drop in impact force and abnormal vibration of hydraulic pipe	Accumulator leakage or bowl damage	Adjust air pressure to specified pressure or replace bowl